

Improving energy efficiency

Major opportunities for energy efficiency and reduction of GHG emissions within a refinery/petrochemical complex are identified. Work process methodology for capturing these opportunities is proposed

Brendan P Sheehan *Honeywell Process Solutions*

Xin (Frank) Zhu *UOP, A Honeywell Company*

The European Union Energy Pact contains key targets for the year 2020: a 20% reduction in CO₂ emissions (compared with 1990) and 20% renewable energy. The CO₂ reduction target will be increased to 30% if a global agreement incorporating other developed nations is reached. However, while results to date have shown some reduction in greenhouse gas (GHG) emissions, it is clear that a lot more effort is required by Member States and the European Community if they are to reach these new targets.

For high energy intensity industries like refineries, a 20% or even a 30% reduction in 11 years seems to be a great challenge, as so far there has been no reduction in emissions for this industry. Future phases of the emissions trading scheme (ETS) may result in the necessity to buy more carbon credits rather than rely on existing allowances. This will put downward pressure on future refinery margins by up to 1–2 \$/bbl, depending on the carbon credit price.

However, recent trends of increasing raw material prices have been driving the refining industry towards a more efficient operation and a more effective energy management policy. This will have an additional effect of reducing GHG emissions, which through the ETS will, in turn, serve to make energy efficiency projects more attractive.

Energy management solutions for refining involve a lot more than just modernising utility systems, although for many sites the utilities plant is an area that has often been neglected. A comprehensive solution combines energy and process optimisation and, where appropriate, incorporates the solution into online advanced control and optimisation strategies. Additional components of the solution include heat and power recovery within and across process units, steam and power system optimisation, feedstock selection, energy contract management, as well as the introduction of renewable energy sources such as biofuels.

Honeywell's experience has shown that a 12–25% energy reduction is achievable by implementing a comprehensive energy management solution, with attractive returns on capital investment.

Trends in energy and GHG emissions

Global trends

The global trends and challenges facing industry are well known. Many countries want to increase their energy security, which has encouraged the search for alternative energy sources and been another driver for energy efficiency. But the recognition of global warming has raised environmental regulations and carbon taxes, setting a new trend that will continue to grow during the coming years. This will add to the operating costs of all energy-intensive industries, including refineries and petrochemical companies. Today's refiners face many challenges that require technology-driven solutions.

EU energy policy

The growth in both population and living standards in the EU Member States since 1990 would, under a normal attitude of "business as usual", have resulted in significantly increased CO₂ emissions by 2020. However, Europe has often been at the forefront of environmental policies and, by signing up to the Kyoto protocol, the EU-15 pledged to reduce GHGs by 8% below 1990 levels by 2012. More recently, in 2007, the expanded EU, now with 27 Member States, ratified a commitment for a 20% reduction in GHG emissions from the 1990 baseline by 2020, and promised to push for an agreement with the US and other developed nations to meet a 30% reduction by the same date. As part of this pact, the EU also committed to producing 20% of its energy via renewable resources by the same deadline.

Recent reports by the European Environment Agency¹ suggest that the

EU-15 Member States can meet their 2012 Kyoto targets, provided they implement all policies and measures currently planned (although not yet implemented in all cases). By 2005, many countries in the EU were already on their way to meeting their Kyoto commitment, with the EU-15 (committed to the 8% reduction) down 4%, while the EU-27 was down 7.9% below 1990 levels. This was achieved by replacing many coal-fired power stations with natural gas and by reducing the emissions associated with transport.

However, it is widely accepted that many of the easy changes have been adopted and that further reductions will require more commitment. With current policies and measures, the EU-27 is not projected to get any lower by 2020 and in fact will increase slightly due to economic growth, particularly in the newer Member States, and the associated increases in energy consumption.

To meet the new targets, many countries will adopt Kyoto mechanisms like the ETS, where countries can buy carbon credits known as emission reduction units (ERUs) from clean development mechanism projects (CDM) or carbon emission reductions (CERs) from joint implementation (JI) projects. This will help them meet some of their reduction requirements, but other measures will need to be adopted. In the current phase of the ETS, individual countries have carbon allowances that are based on the normal operation of its various industries and, provided each business stays below its cap, no direct impact is felt. If a site exceeds its cap, it has to buy carbon credits to offset the excess carbon emitted during the trading period. After ETS II is complete in 2012, a new ETS phase will begin. Although the conditions for the new trading period have not yet been defined, it is likely that allowances will be dramatically reduced and many more carbon credits will have to be purchased, which will significantly raise the cost of CO₂

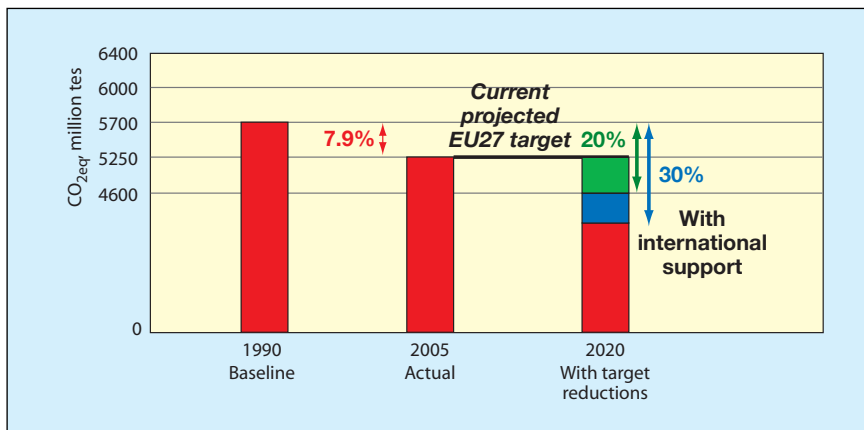

Figure 1 EU GHG emissions targets

emissions. At the time of writing, carbon credits in ETS II were trading between 22–25 €/te.

Many new measures will be needed, including the promotion of electricity from renewable energy sources, cogeneration directives and the use of biofuels. The current contribution of renewable energy is mainly from hydroelectric power and totals about 6.7% of total energy consumption.

Energy and GHG emissions in refining

So what does all this mean for the refinery and petrochemical industry? Most European refineries currently have sufficient carbon allowances and, in fact, CO₂ emissions have been rising due to increased demand for refining products and the need by refiners to process heavier, more sour crude feedstock. However, this situation is unlikely to remain, particularly if allowances are

significantly reduced during the next trading scheme. In that case, the cost of CO₂ emissions will have to be incorporated into the overall cost of operation.

But it is not the impending rise in CO₂ emissions that is driving change today, but rather the high cost of crude feedstock. Crude oil prices increased from \$70/bbl in October 1997 to \$145/bbl in June 2008, before falling back to \$80/bbl in October 2008. Nevertheless, most economists forecast that energy prices are likely to remain high over the period between now and 2020, which has made it imperative for refineries to focus on reducing energy costs. This action will directly result in reduced GHG emissions.

Energy costs for a typical refinery are 50–60% of total operating costs, not including the cost of feedstock. This figure is based on a natural gas price of about \$6/MMBtu. Recent natural gas

prices have been significantly higher, making energy costs as a percentage of total operating costs even higher. A typical 100 000 BPSD refinery spends \$80–100 MM/year on energy. An energy-efficient refinery might spend as much as 25% less than a comparable competitor. This does not include the value of the associated reduction in CO₂ emissions, which could add a further 10–12% if there were no allowances and all carbon emissions had to be paid for. Hence, refiners realise that improving energy efficiency will help them reduce operating costs and increase margins, and tightening CO₂ regulations within their industry will only serve to make these energy-related projects more attractive economically.

Energy-saving opportunities Opportunities for saving energy and reducing GHG emissions

If a refiner wants to reduce energy costs and GHG emissions, which areas should demand the most attention and what should proposed solutions look like? CO₂ emissions vary from refinery to refinery, depending on feedstock type, fuel specifications and refinery complexity. A typical 100 000 BPSD refinery emits 1.2–1.5 MM MT/yr of CO₂. About 50% of that is from the process heaters, 35% from the FCC and hydrogen plants, and the rest from steam and power systems. Similarly, the energy consumed within a refinery varies with configuration and feedstock, but the major energy consumers are the crude unit, FCCU, reformer and utilities.

At the current time, focusing on reducing energy costs is the best way to reduce GHG emissions, as it removes the concern of where the future value of carbon credits will settle. The following sections will examine where these opportunities for reducing energy lay, and will describe in detail some of the solutions that are available. As shown in Figure 2, energy GHG emissions savings can be realised by:

- Using energy more efficiently within the process
- Buying or producing energy cheaper
- Leveraging environmental policies to gain carbon credits to offset energy costs.

Improving energy efficiency within the process can be achieved in a variety of ways, ranging from little or no capital cost operational improvements to optimise the process, recovering more heat by improving the heat integration of the process, or adopting new process technology that fundamentally improves the efficiency of the operation.

Getting energy cheaper can be achieved either by producing energy more cheaply through optimisation of on-site steam and power utilities plant, or by buying feedstock that both meets the forecasted product demand mix and minimises

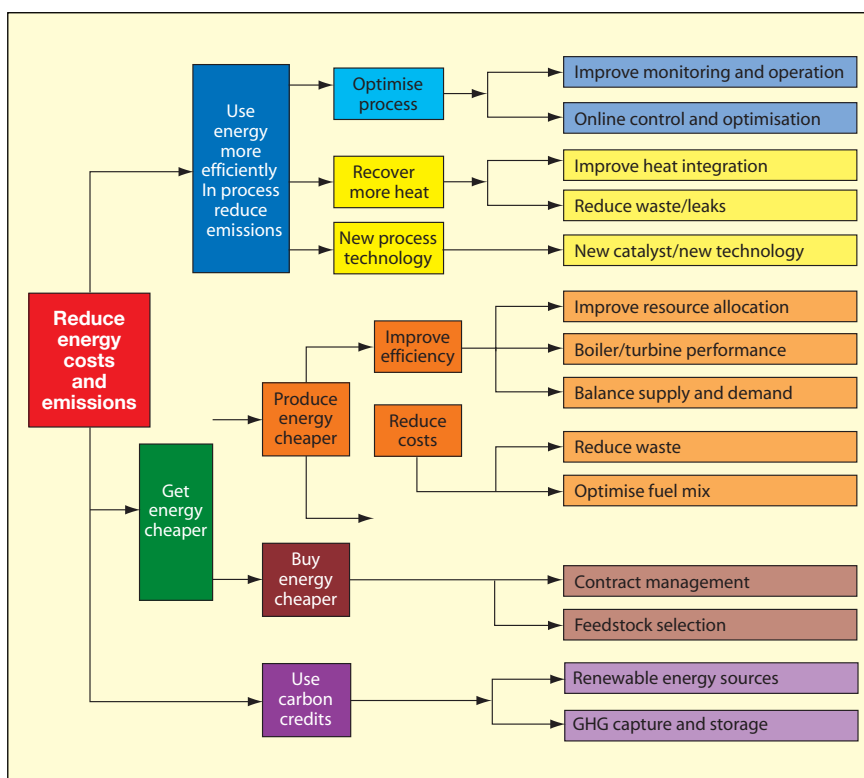

Figure 2 Energy saving opportunities

energy consumption within the process.

Producing energy based upon renewable sources such as biodiesel or green diesel can enable a refinery to obtain carbon credits associated with this production that can help offset the additional cost of production.

Improve energy efficiency: optimise operation

The first step in developing an energy management solution to optimise the process is to be able to measure what energy consumption looks like against a reasonable set of benchmarks. This involves capturing energy data related to the process and organising it in a way that allows operations to quickly identify where the big energy consumers are and how well they are doing.

To determine how well a plant or a unit is doing, it is necessary to be able to compare current energy use against a consumption target that reflects the current operations. Only then is it possible to do some analysis to determine the cause of deviations from target and take appropriate remedial action.

A good energy-monitoring solution should perform like John Boyd's OODA loop², which allows the user to quickly observe the situation and assess the relative performance of multiple units; orient themselves by being able to drill down to get more details on key energy indicators of the most critical areas; decide on a set of possible actions based upon the determination of possible causes for deviation from target; and act quickly and decisively based upon a set of well-informed decisions. The loop allows for rapid internal feedback to allow the user to quickly observe the impact of actions taken and hence reorient and decide on further actions.

A hierarchy of views is provided by the energy-monitoring application that allows the user to drill down to multiple levels and identify possible actions. These include:

- **Unit overview** Shows the relative size of energy consumption and/or GHG emissions in each unit. Also uses colour coding to indicate which units are furthest away from target

- **Unit view** Shows the value of key energy indicators (KEIs) that describe the energy performance of the unit against targets, which are developed from a combination of process simulation, historical data and know-how of experienced consultants. These predicted energy targets are automatically adjusted to reflect current operating conditions such as production level, operating mode and feed composition

- **Trend KEIs** Allows the trending of the calculated value of KEIs against both the planning target and the predicted energy target

- **Review deviations** In this display,

the operator can review over time the periods when KEIs deviated significantly from their expected range and what the major causes of the deviations were according to the selected reason codes. By building up a history of causes, it is possible for the user to look back over time and see the most common causes for deviations. This can lead to recommendations about modifications to improve energy performance.

Many recommendations for improving energy efficiency can be achieved by the operator directly, changing the plant conditions by adjusting the set point of key variables. In some cases, it may be possible to incorporate these recommendations

into an online advanced control and optimisation strategy.

Multivariable, predictive control and optimisation applications such as Honeywell's Profit Controller have been commonly applied to refinery and petrochemical processes. The ability to take models derived from process data and configure them in a highly flexible manner allows the engineer to design controllers that can be suitable for many purposes. The same controller can be used to maximise throughput, maximise yields and minimise energy just by changing cost factors in the objective function. This environment is very suitable for incorporating energy strategies into overall operating

objectives. In fact, it is generally advisable to add energy efficiency objectives into existing strategies, as it is important that minimising energy is not done at the expense of maintaining yields of most valuable products. In more complex solutions, rigorous simulation models can be used to update data models within the controller.

Many energy-saving strategies can be incorporated into multivariable control applications such as:

- Furnace pass-balancing and excess O₂ control
- Distillation column quality controls combined with pressure minimisation to maintain yields of most valuable products, while minimising energy consumption up to constraints such as tower flooding
- Reactor conversion control
- Feed preheat maximisation
- Separator and recycle control.

An example of a large multivariable control strategy was applied to an ethylene complex. This involved a total of 17 multivariable controllers that were linked together by an over-arching optimisation strategy that included the use of a non-linear cracking model to predict product yields.

The result of the project was to enable the customer to increase feed rate by 3% over the previous best rate by being able to operate the process up against multiple constraints simultaneously. In addition, the application was able to reduce energy consumption by 3.25% by reducing steam consumption in the fractionators and minimising excess O₂ in the furnaces. This resulted in a payback of less than five months.

Opportunities to operate process units more efficiently exist in most refineries. In Honeywell's experience, little or no capital operational solutions can improve energy efficiency by 2–4%. These improvements can reduce CO₂ emissions by 24 000–48 000 MT/yr for a typical 100 000 BPSD refinery.

Improve energy efficiency: better heat recovery

Using monitoring and optimisation software to improve energy efficiency usually results in pushing the process up against multiple physical constraints. To get to the next level of energy efficiency requires capital cost modifications to increase heat recovery within and across process units. Indeed, one of the key values of implementing operational solutions first is that it more clearly highlights where to find the physical constraints to the process. Once specific units have been identified for improved heat integration, pinch technology, in software such as Honeywell's Unisim Design, can be applied to efficiently screen and select from a variety of possible heat recovery networks. UOP

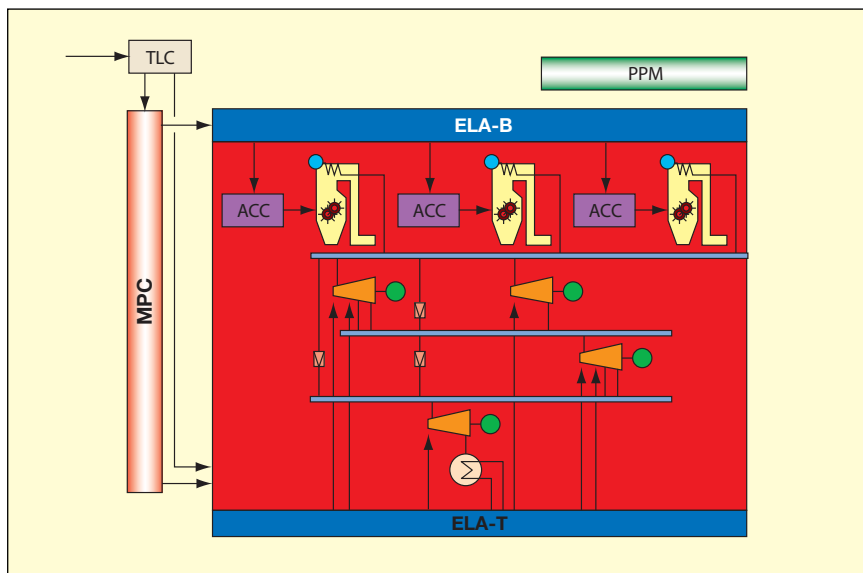

Figure 3 Honeywell's Advanced Energy Solution (AES) for utilities

process consultants use a practical methodology, which not only considers value and cost of improved heat recovery, but also the impact in terms of operating flexibility, especially with respect to start-up, shutdown, maintenance and control.

A typical example of redesigning for improved heat recovery involved a 1970s vintage diesel hydrotreating unit that had a combined feed exchanger, charge heater, one reactor and a stripper. When UOP process consultants studied this unit, they recommended adding four heat exchangers to recover more heat from the process and also to generate steam. This scheme reduced the product rundown temperature by 107°C and the temperature to the products condenser by 150°C, which reduced the amount of heat lost in the fin fans. The capital cost for this project was estimated to be \$3 MM, but resulted in energy savings of \$4.5 MM per year.

Projects to improve process unit heat recovery can improve energy efficiency by 4–8%. The CO₂ reduction for a typical 100 000 BPSD refinery that results from these projects is 48–96 MT/year.

Improve energy efficiency: advanced process technology

Improved heat recovery is the most common type of capital project implemented to improve energy efficiency. However, recent work by UOP has identified others areas less commonly explored that may provide significant opportunities. Many of these areas make use of advanced process technology offered by UOP, such as enhanced heat exchangers, high capacity fractionator internals, new reaction internals, power recovery turbines, improved catalysts and other design features.

Power recovery often represents a good opportunity for economic energy optimisation. In a study of an FCCU with

60 000 bpd throughput, the FCC catalyst regeneration flue gas was being used for steam generation alone via a waste heat steam generator. A power recovery system was quickly identified as a method for significant energy efficiency improvement, as the flue gas could be used for both steam and power generation simultaneously. Further improvement could be achieved by installing a power recovery turbine (PRT) combined with a steam turbine. The goal was to generate electricity from the regenerator flue gas, but also produce electricity from high-pressure (HP) steam letdown to make the medium-pressure (MP) and low-pressure (LP) steam required in the FCCU. Compared to a base case that does not include a PRT and uses a condensing steam turbine to drive the main air blower, this scheme has a net energy benefit of \$14 MM per year.

There are a variety of advanced technologies that can be applied, which vary in terms of cost to implement and return on investment. Careful evaluation of each of these solutions is required, as capital is always limited, so it is necessary to select only the best opportunities that provide the highest return on capital employed. Although these solutions can vary greatly, typical improvements to energy efficiency are 3–8% for a typical 100 000 BPSD refinery. The CO₂ reduction is 36 000–96 000 MT/year.

Produce energy cheaper: utilities optimisation

In addition to using energy more efficiently in the process, another common strategy is to produce energy more efficiently. Many refineries and petrochemical sites have their own on-site industrial power plants that primarily exist to provide steam and power to the process units, but may also supply electricity to the grid at times of excess capacity. One of the keys to reducing energy costs in utilities plants is to

balance changing energy demands from the process with adequate supply from the utilities plant without wasting energy by keeping spare capacity on standby.

Honeywell has recently released its Advanced Energy Solution (AES) for utilities. Built on the same foundation as Honeywell's Profit Suite solution, AES is an integrated but modular advanced control solution that has been specifically designed for industrial steam and power plants. It is made up of a number of components that can be combined to address the needs of a broad set of utilities unit configurations and operating modes. The components include the following:

- Advanced combustion control for solid, liquid or gas fuel fired boilers. A sophisticated optimiser is used to tightly control fuel-to-air ratio, while continuously evaluating emissions using measurements of flue gas components (O_2 , CO , NO_x)

- Master pressure control that uses a dynamic model to stabilise multiple header pressures by predicting future manipulated variable moves

- Economic load allocations of boilers and turbines. ELA for boilers uses boiler efficiency curves to distribute the total heat requirement among all the boilers in the lowest cost manner. However, it also aims to maintain the widest effective steam production range. Combined with the master pressure control, this strategy allows for the fastest dynamic response while trending to the most economic steady state position. ELA for turbines can operate in pressure control mode, where the turbines aim to maximise power generated while maintaining steam pressure, or in power generation mode, where steam consumption is minimised while maintaining a total generated power target

- Supply and demand optimisation is achieved by a simulation of the utilities plant that can take a set of process forecasted demands from the production schedule and determine the configuration and operating profile of the boilers and turbines to meet demand, while taking into account tiered pricing, power contracts to the grid, and environmental limits on NO_x and CO_2 emissions. The simulation can include cases for changing discrete variables to determine the best choice of fuel to boilers or energy input to dual drive motors.

This suite of applications was applied to a petrochemical site in Korea. The plant had three oil-fired boilers and three back pressure steam turbines that provided steam and power to the process units and also supplied excess power to the national grid. The solution used the advanced combustion controls, the master pressure controls for three headers, and economic load allocation across the boilers and the turbines. The

results from the implementation led to a significant reduction (>10%) in CO_2 and NO_x emissions, and improved boiler efficiency, leading to overall benefits of more than \$1 million/year.

Optimisation of the energy supply system can typically improve energy efficiency by 23% for a typical 100 000 BPSD refinery. The corresponding CO_2 reduction is 24–36 000 MT/year.

Buy energy cheaper: improved planning and scheduling

Another supply-side method for improving energy efficiency is to determine the most cost-effective feedstock to run in the refinery or petrochemical complex and still meet the product slate required by customer demand. As mentioned earlier, this may include energy products such as exporting electricity to the grid in deregulated energy markets.

The primary mechanism for buying cheaper energy is to use planning and scheduling applications to optimise how the plant meets forecasted demand over an extended period. Refinery planners consider the variety of crude oil feedstocks that can be processed in their units and how they might be blended, based upon their assay data, to keep the plant full and still meet demand. Information about yield and quality data of different crude fractions provide input to the operational plan along with knowledge of process unit configuration, material availability and price. An LP planning tool, such as Honeywell's RPMS, can incorporate product mix limits, energy costs and even CO_2 emissions limits, or costs to find the feedstock that optimises the profitability of the plant.

This planning application helps determine how much of a particular feedstock should be run, but it does not provide the granularity necessary for detailed operating instructions.

The plan is executed by converting it into a sequence of feasible activities over

a short time horizon of a few days or weeks. This can be a complex step and many planners will use spreadsheets to help them come up with a feasible operating schedule. They will often adopt the first feasible solution they find, knowing it may have to be updated on a regular basis. The use of a scheduling model, such as Honeywell's PS2, enables the user to find the optimal schedule that maximises profitability, while honouring quantity, quality and logic constraints. This model can be run as often as required to reflect any changes in conditions in the plant or in feedstock availability.

An example of where planning was used to select the best feedstock for the plant involves a refinery with a downstream ethylene complex, which had recently built a new ethylene plant and wanted to figure out how it should keep the new unit full. It considered options of buying in naphtha feed or feeding atmospheric gas oil (AGO) to the ethylene tower. It also considered how things would change if a new crude atmospheric tower was added, thus increasing the amount of crude feedstock that could be processed. The solution involved considering a range of options in both configuration and feedstock selection, and integrated the changing energy costs. For constant throughput, (ie, no new atmospheric tower) it found that buying naphtha was cheaper than feeding AGO to the ethylene unit. However, the answer changes if the company decides to increase crude throughput by adding a second atmospheric tower — now there is too much AGO available and it is best to run it through the ethylene plant rather than buy in additional naphtha.

Optimisation of the feedstock selection by improved planning and scheduling can typically improve energy efficiency by 1–2% for a 100 000 BPSD refinery. The corresponding CO_2 reduction is 12 000–24 000 MT/year.

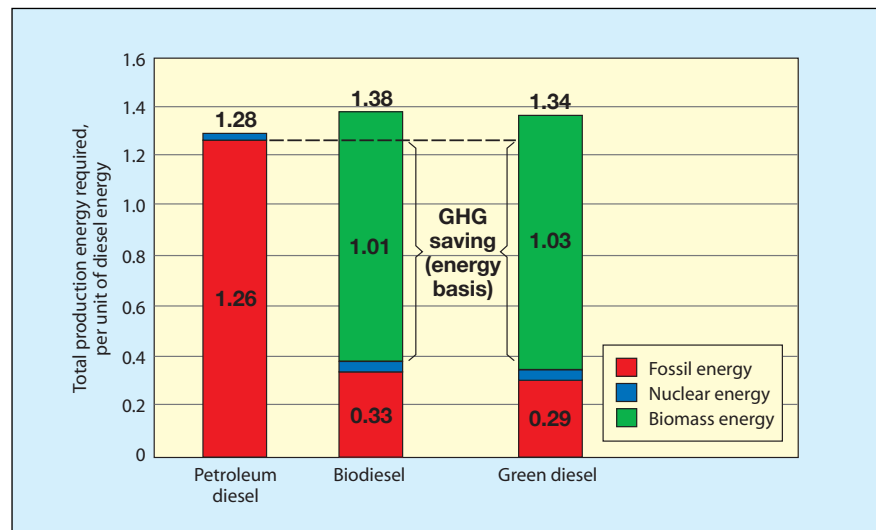

Figure 4 Life cycle assessment of green diesel vs petroleum diesel

Achievable benefits from comprehensive energy management programme

Area of saving	Energy improvement, %	Energy saving, MMS\$/yr	CO ₂ reduction, kMt/yr
Improved operation and control	2–4	1.5–3	24–48
Improved heat recovery	4–8	3–6	48–96
Incorporate advanced process technology	3–8	3–6	36–96
Utilities optimisation	2–3	1.5–2.5	24–36
Improved planning	1–2	1–1.5	12–24
Incorporate renewables (2000 bpd Ecofining unit)	CO ₂ credit	4	116
Total	12–25	14–23	144–416

Table 1

Leverage environmental initiatives: use carbon credits

Aside from improving energy efficiency to reduce CO₂ emissions, you can also tackle the problem by focusing on increasing the amount of renewable energy processed. This not only helps meet the EU directive for 20% renewable energy by 2020, but also improves profitability by the resulting carbon credits that can be obtained.

Figure 4 shows a life cycle assessment (LCA) for petroleum diesel, biodiesel and green diesel.³ Biodiesel, as shown here, is existing technology to produce fatty acid methyl esters (FAME) via transesterification of oils with methanol. Second-generation green diesel is produced by hydrotreating those same biofeedstock — in this case, vegetable oil from soybean.

The LCA, which was conducted according to ISO14040 standards, shows the total energy expended per unit of final product fuel energy, taking into account all of the energy involved in the production of green diesel from soybean and hydrogen, and compared to biodiesel and petroleum diesel. This includes the life cycle stages of soybean cultivation and harvesting, transportation, crushing to oil and conversion to green diesel. The amount of nuclear energy consumed is derived from the mix of electricity-generating sources used to provide the electricity involved in production.

Only fossil fuel-derived GHG

emissions are considered here, so the biomass energy is considered to be net zero with respect to GHG emissions. Consequently, while the total energy required to produce green diesel is slightly higher than petroleum diesel, the energy consumed by fossil fuels only is 77% less than petroleum diesel and the GHG emissions are 84% less.

GHG emissions reduction is a key criterion for the sustainability of the biofuels industry. The installation of a biofuels unit can lead to significant GHG savings by reducing an entity's carbon footprint. An example is the proprietary UOP/ENI Ecofining process, which converts vegetable oil such as soybean, palm and rapeseed to green diesel, but could also process other low-cost materials such as tallow oil, fish oils and waste greases. The process deoxygenates the feed and uses hydrogen to convert the oil to a branched paraffin-rich diesel fuel. Water and CO₂ formed by the deoxygenation process are separated from the product, while excess hydrogen is recovered and recycled back to the reactor to maintain the minimum required hydrogen partial pressure.

The reduction in GHG emissions for a 2000 BPSD Ecofining unit is worth 116 000 MT/yr of carbon credits.

Potential savings

Table 1 combines all of the potential energy and GHG emissions initiatives to provide a perspective on the level of

benefits a typical refinery of 100 000 BPSD could achieve by adopting a comprehensive energy management programme. Recent studies by UOP consultants indicate that typical benefits of 12% energy reduction are expected rising to 25% for refineries operating in the fourth quartile for energy efficiency. The carbon credits associated with the reduction in GHG emissions range from 144 000–400 000 MT/yr, which at prices of \$30/MT is worth between \$4 million and \$12 million/yr.

The potential benefits of these initiatives are substantial, but given the broad spectrum of solutions that have been described, what capabilities would a company need to deliver them?

Work process methodology

Capability requirements

A provider of energy and CO₂ solutions to the refining industry needs several capabilities to be effective. The provider needs deep domain expertise in energy efficiency and process technology across the process units, and in particular how they interact with the utilities system. Given that a refinery often has many opportunities for energy saving, the ability and experience to benchmark the plant and identify practical solutions is critical. It is important to be able to differentiate between realistic solutions and those that indicate potential savings but reduce flexibility during start-up, shutdown or emergency procedures, making them impractical.

Operations expertise is required to help a refiner identify and implement no-capital cost operational solutions. Advanced automation expertise is required to be able to automate data gathering, convert the data into useful information and provide easy-to-use interfaces that enable operators to quickly identify deviations from expected energy performance and the potential causes. Experience in simulation, advanced control and optimisation solutions enables the implementation of strategies designed to continually push the plant towards its most energy-efficient state, which will help to highlight where the physical process bottlenecks exist.

The provider of energy solutions should also be experienced in providing detailed engineering services to design equipment and additional automation solutions to relieve these bottlenecks. Finally, aftermarket software and services are required to help the refiner sustain the energy benefits and continuously improve performance over time.

Energy and CO₂ emissions solution methodology

UOP and Honeywell Process Solutions (HPS) have combined their expertise and resources to provide a work process methodology for implementing energy

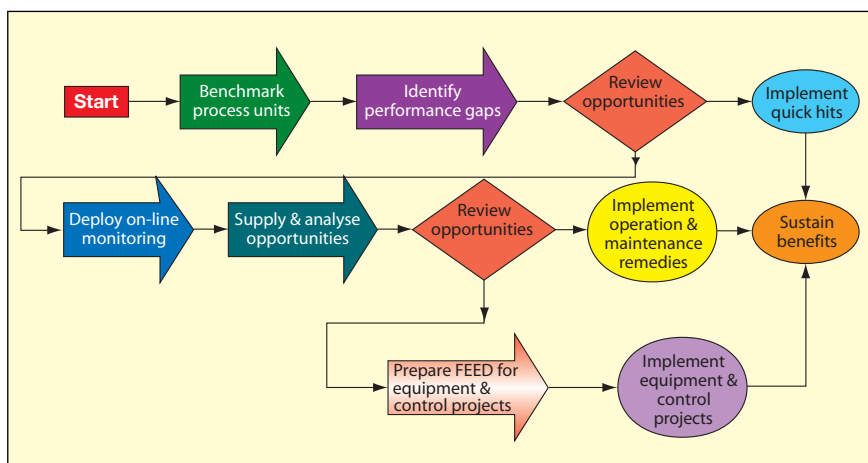

Figure 5 Honeywell energy/CO₂ emissions solution — work process methodology

projects. The first step shown in Figure 5 is to benchmark the process units and identify performance gaps. This helps focus the analysis on the best opportunities. It also usually leads to operational improvements or quick hits that can be implemented immediately. Energy-monitoring application software is used to monitor the facility and identify the performance gaps, as well as provide inputs into the detailed study and analysis step.

Once the best opportunities are identified and analysed, the refiner chooses which projects to implement. At the same time, some advanced control and optimisation applications, along with other operational and maintenance solutions, will be implemented, where benefits can be realised that do not require capital equipment modifications. The capital projects that the refiner chooses to implement usually go through a FEED phase to complete the engineering and confirm the capital costs. The next step is to choose a contractor to implement the capital projects, which will consist of process equipment changes, and changes to the control system architecture and associated software applications.

The last step in the process is to sustain the benefits from the energy projects that have been implemented. Honeywell provides the software and services to help the refiner maintain the value of their capital investment by continuously monitoring, maintaining and improving the performance of the implemented energy programme.

The only way this type of solution can be provided is by forming a partnership with the refiner throughout the course of the programme and staying involved in each step of the entire process. The objective is to work with the refiner through every stage: from benchmarking and opportunity assessment through implementation of operational and capital solutions, and through the post-implementation period of sustaining benefits. UOP and HPS prepare the basic engineering design specifications and work with a contractor (either one partnered with Honeywell or commonly used by the refiner) to complete the FEED package. The contractor will always be involved to implement the capital projects, but Honeywell will stay involved and continue to take responsibility for successful implementation.

The objectives of the new work process are to improve the integration between the refiner and the solution provider, and provide a mechanism through which the refiner can obtain guaranteed, sustainable benefits. Honeywell is willing to offer guarantees, which ensure their full involvement during all phases of the project.

Given the EU's commitment to

reducing GHG emissions by 20% below 1990 levels by the year 2020, the most appropriate way to achieve this is to focus on reducing energy costs and emissions by:

- Improving energy efficiency within the process units
- Reducing the cost of producing energy through feedstock selection and utilities optimisation
- Leveraging Kyoto mechanisms to gain carbon credits through the use of renewable energy sources.

Honeywell's experience has shown that a 12–25% energy reduction is achievable by implementing a comprehensive energy management

solution with attractive returns on capital investment.

This article is based on a presentation from the recent ERTC in Vienna.

References

- 1 *Greenhouse gas emissions trends and projections in Europe 2007*, EEA Report 5/2007.
- 2 Coran R, Boyd: *The Fighter Pilot Who Changed the Art of War*, 2002.

Brendan P Sheehan is Senior Marketing Manager, Vertical Industries, Honeywell Process Solutions in Phoenix, Arizona.

Xin (Frank) Zhu is Senior Energy Consultant, Optimization Services, UOP, A Honeywell Company, in Des Plaines, Illinois.